

# DNA Probing System by High Tc SQUID and Ultra-small Magnetic Particles

SABURO TANAKA

*Dept. Ecological Engineering, Toyohashi University of Technology, Toyohashi 441-8580, Japan*

phone: +81-532-44-6916, fax: +81-532-44-4929

e-mail: tanakas@eco.tut.ac.jp

High Tc SQUID system for Biological molecules (DNA) detection is developed. This system is based on a hybridization process. Two strands in a DNA molecule are held together by hydrogen bonds between base pairs like a ladder. The two strands are referred to as being complementary each other. HPV33 (Human Papillomavirus Probes 33 bases) was prepared as a DNA. One strand (Sample DNA) was labeled with Fe<sub>3</sub>O<sub>4</sub> ultra-small magnetic particles and the other (probe DNA) was anchored on a glass slide. Then they were hybridized each other on the slide. After washing the excess sample DNA, the hybridized DNA was evaluated in the presence of excitation ac field by high Tc SQUID. The signal was initially proportional to the concentration of the sample DNA and then saturated. It means that the hybridization occurred successfully between the sample DNA and the probe DNA

## 1. Introduction

Analysis of biological molecules DNA is based on separation and detection process. The detection method for the separated molecules determines the total sensitivity of analysis system. To date, several methods have been introduced for the detection to improve the sensitivity. Radioisotope labeling method is a one of most common methods [1]. However it requires a special facility, which confines radioisotope. Fluorescence labeling method is very high sensitive. It can detect only single molecules, however quenching of fluorescence dye inhibits long time observation [2]. Enzyme labeling method also achieves high sensitivity, however enzymes are sometime unstable [3]. A labeling method with small magnetic particles has been introduced. SQUID has a large potential to detect small amount of these particles because of its high sensitivity for magnetic field. Detection of small magnetic particles with a SQUID for immunoassay applications is performed in several groups [4]-[7]. Recently sensitive DNA chip technique has been developed. Because DNA chip loads enormous numbers of different DNA probes which correspond to genetic disease or personal properties, those have been applied to analysis of polymorphism of human genome. To apply high Tc SQUID sensor for DNA chip detection, we have developed a detection system and a sample preparation method [8]. In this paper, a hybridization of DNA with relatively short length was investigated. One strand (Sample DNA) was labeled with Fe<sub>3</sub>O<sub>4</sub> ultra-small magnetic particles and the other (probe DNA) was anchored on a glass slide. They were hybridized each other on the slide. Then the hybridized DNA was evaluated in the presence of ac excitation field by high Tc SQUID. This method is classified into a category of susceptibility measurement.

## 2. Detection System

### 2.1 System

The detection system is schematically drawn in Fig. 1. The SQUID is made of Y<sub>1</sub>Ba<sub>2</sub>Cu<sub>3</sub>O<sub>7-y</sub> thin film. The junctions utilized in the SQUID are of the bi-crystal type. The washer size of the SQUID is about 5 x 5 mm<sup>2</sup> and the effective area is 0.05mm<sup>2</sup>. The SQUID was operated in a flux-locked loop with a flux modulation frequency of 256kHz. The cryostat (not shown in the figure) was specially designed for a SQUID microscope. The SQUID was located inside a vacuum and separated by a quartz window. A more detailed description can be found elsewhere [9], [10]. A set of excitation coil is mounted above the SQUID microscope. This excitation coil generates magnetic field of 100Hz and modulates the SQUID signals. The maximum applied magnetic field was 0.43mT at peak to peak value. The relative position of the SQUID and the excitation coil was carefully adjusted so that the SQUID

output signal without particles became zero. Compensation coil wound around the SQUID was employed to be able to cancel the residual vertical component of the excitation field, which could not be canceled by the adjustment. A Phase shifter was used for adjusting the phase of the field current. In the measurement, the sample was driven with a speed of 10 mm/sec by a stepping motor, which was installed outside a magnetically shielded room. When the sample passed above the SQUID, the SQUID output signal was lock-in amplified and recorded by PC recorder. A high pass filter (HPF) with frequency of 0.01Hz and band elimination filter (BEF) with frequency of 60Hz were used. The schematic of the sample carrier is shown in Fig. 2. The sample carrier is made of glass and its dimension is 7 mm x 4 mm x 0.9mm. It has a hole of 3mm in diameter. After filling the hole with a liquid sample, it was covered with an adhesive tape. When the sample was measured, it was turned over so that the side of adhesive tape faces the SQUID. The distance between the sample and the SQUID was adjusted at as close as about 0.8mm.

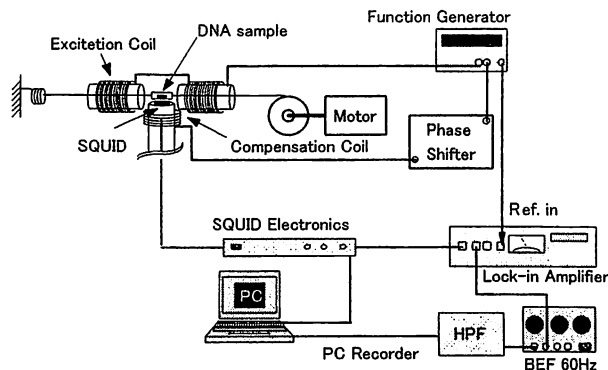

Fig. 1. Schematic diagram of the DNA detection system. SQUID Output signal is lock-in amplified and recorded by a PC recorder.

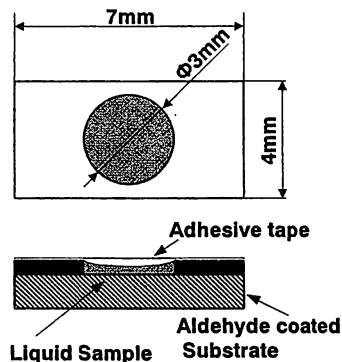

Fig. 2. Schematic drawing of the sample carrier. The size of the glass slide is 7 mm x 4 mm x 0.9mm. It has a hole of 3mm in diameter. After filling the hole with a liquid sample, it was covered with an adhesive tape.

## 2.2 Noise

The magnetic flux noise spectrum of the system is shown in Fig. 3. The flux noise in the white noise region was about  $12 \mu\phi_0/\text{Hz}^{1/2}$ . After applying the excitation magnetic field of 0.43 mT, the white noise was increased by a factor of 20. However neither major flux trapping or flux jump happened. A blank sample carrier was moved above the SQUID and the signal was recorded to estimate the background noise. Fig. 4 shows the recorded signal trace of the blank sample. The peak to peak value of the noise is about  $7 m\phi_0$ .

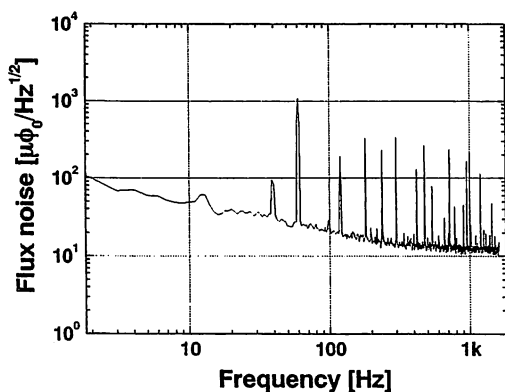

Fig. 3. Flux noise spectrum of the detection system. White noise is about  $12 \mu\phi_0/\text{Hz}^{1/2}$ . Microphonic noise at 40Hz, power frequency noise at 60Hz and their harmonics can be seen.

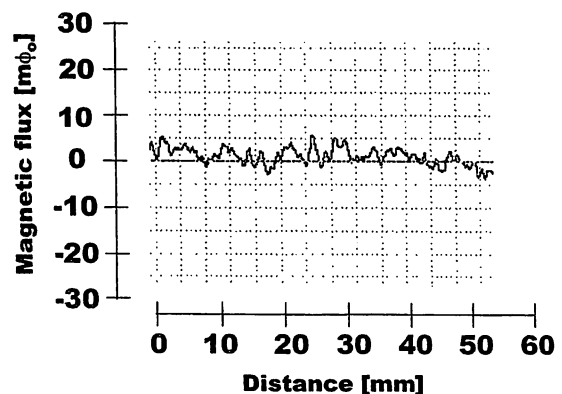

Fig. 4. Signal trace of the blank sample. The peak to peak value of the background signal is about  $7 m\phi_0$ .

### 3. Measurement

#### 3.1 Magnetic nanoparticles

We used nanoparticles from Meito Sangyo Co., Ltd. The core of the particle is iron oxide  $\text{Fe}_3\text{O}_4$  (magnetite) which is coated with a dextran [11]. The averaged core diameter and the outer dimension of the particles were 11nm and 65 nm respectively. The particles had superparamagnetic properties. The COOH group is attached around the surface of the dextran. The DNA will be connected to the COOH group via a proper linker. The particles were supplied in the form of an aqueous magnetic fluid. The concentration of the particles in the original fluid is 36  $\mu\text{M}$ . The original fluid was diluted with distilled water to have the desired concentrations. We took 4 $\mu\text{l}$  of each liquid sample with desired concentration and put it on the glass sample holder shown in Fig.2. The holder was covered with an adhesive tape and then moved above the SQUID. The recorded typical signal trace is shown in Fig.5. This sample contains 0.73 pmol of nanoparticles. The peak to peak value shows magnetic field of 100  $\text{m}\phi_0$ . Fig.6 shows the magnetic signal measured by the SQUID when the number of the particles is changed. The signal is almost proportional to the number of the particles.

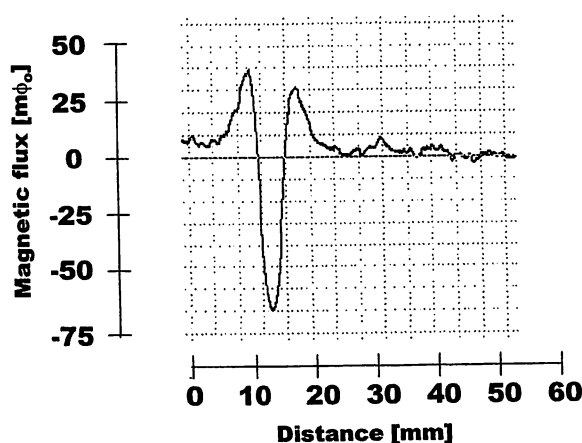

Fig. 5. Typical signal trace of a liquid sample with particles. This sample contains 0.73 pmol of nanoparticles.

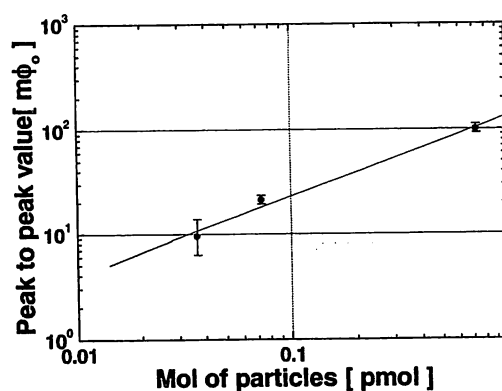

Fig. 6. Magnetic signal v.s. number of particles. Volume of the sample is 4 $\mu\text{l}$ . The signal is almost proportional to the number of the particles.

#### 3.2 DNA Sample

We employed single strand DNA (ssDNA) with relatively short length, 30 base pairs (Human Papillomavirus Probes 33). The sequence of the strand is CATAG TCGTA CAGTA CCTTA CTGCA AAATG and its complement. One ssDNA named sample DNA was modified with amino group ( $\text{NH}_2$ ) at 5' terminal. This amino group can be connected to the carboxyl group COOH of the nanoparticle via crosslinker [12]. The crosslinker which consists of EDAC (1-Ethyl-3-(3-Dimethylaminopropyl) Carbodiimide hydrochloride) and Sulfo-NHS (N-Hydroxysulfosuccinimide) is reacting as a connector between the ssDNA and magnetic nanoparticle. The other ssDNA named probe DNA was labeled with  $\text{NH}_2$  at 5' terminal and fluorescent Cy3 at 3' terminal. This  $\text{NH}_2$  is reacting as a linker between ssDNAs and the substrate and Cy3 was used for confirming whether the ssDNAs were anchored on the substrate.

First, we prepared particles connected with ssDNA. The concentration of the particles and that of ssDNA are 0.856 $\mu\text{M}$  and 2.35 $\mu\text{M}$  respectively. This ratio determines the number of ssDNA on the surface of the particle. According to this ratio 2.35/0.856, it is estimated that one particle has about three ssDNA on its surface. Then the solution containing the particles with ssDNA was diluted to prepare solutions with different concentrations. These solutions were used as sample DNA through the experiments.

Second, we prepared probe DNA with a concentration of 10mM, which is labeled with  $\text{NH}_2$  at 5' terminal and fluorescent Cy3 at 3' terminal. 2  $\mu\text{l}$  of the probe DNA was taken and put on an aldehyde coated glass substrate, which dimension is the same as the sample carrier shown in Fig. 2. Volume of 2  $\mu\text{l}$  corresponds to 20 pmol of probe DNA. Fig.7 shows the fluorescence microscope image from Cy3 of probe DNA on the aldehyde coated substrate. (a) and (b) show the image of before wash and after wash respectively. (c) indicates schematic of the DNA on the substrate. All probe DNA including some floating DNA can be seen before wash. However, most of DNA has gone and some DNA can be seen after wash. This means that 1-5 % of probe DNA, which corresponds to 0.2-1 pmol of the DNA, was anchored on the substrate. Although this efficiency should be improved in the future by optimizing the condition of the reaction between  $\text{NH}_2$  and Aldehyde, this anchored DNA can be used for following hybridization experiments.

Here, we tried to make hybridization on the substrate. After applying 20 pmol of the probe DNA, unbound DNA was washed. Then the particles with sample DNA were applied to the substrate. After wash the excess DNA, which was not hybridized with probe DNA, the sample was measured. Several sample DNA with different concentration were applied to the probe DNA. The concentration of the probe DNA was constant and 20 pmol. Fig.8 shows the relation between the magnetic signal and the mol of sample DNA. Signal shows a tendency of slow increment more than at about 5 pmol of the DNA.

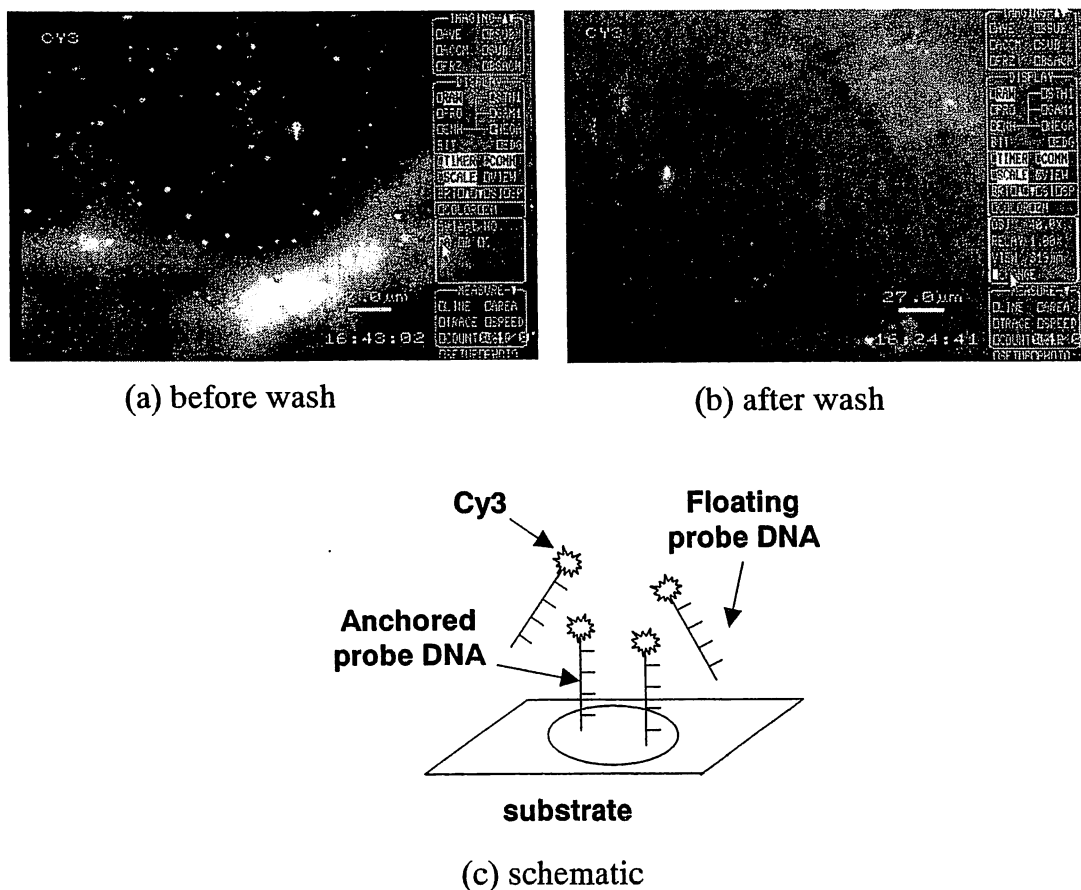

Fig. 7. Fluorescence image of probe DNA on the aldehyde coated substrate. (a) Before wash. (b) After wash. (c) Schematic drawing of the DNA on the substrate. After washing floating DNA, the number of the DNA decreased.

#### 4. Discussion

Horizontal axis in Fig.8 shows the number of sample DNA applied to the probe DNA. The real number of residual sample DNA devoted the hybridization on the substrate must be smaller than this number because the excess DNA was washed before the measurement. Therefore, we estimated the

real number of DNA devoted the hybridization using a relation between the signal and the number of particles as shown in Fig.6. By the estimation, it is known that the 5 pmol of DNA in Fig.8 corresponds to 0.07 to 0.2 pmol of the nanoparticles. Since the one particle has about three ssDNA, the number of DNA devoted the hybridization can be calculated and becomes 0.2 to 0.6 pmol. This number is almost consistent with the number of probe DNA on the substrate after wash. Thus the properties on Fig.8 implies that the signal increases along with the number of the sample DNA and then shows the tendency of saturation at the number of the probe DNA on the substrate. Therefore it is found that the signal does not increase even if the number of the applied sample DNA was increased at more than 0.2-0.6 pmol, because the reaction is determined by the number of probe DNA on the substrate. This result indicates that the hybridization was successfully done.

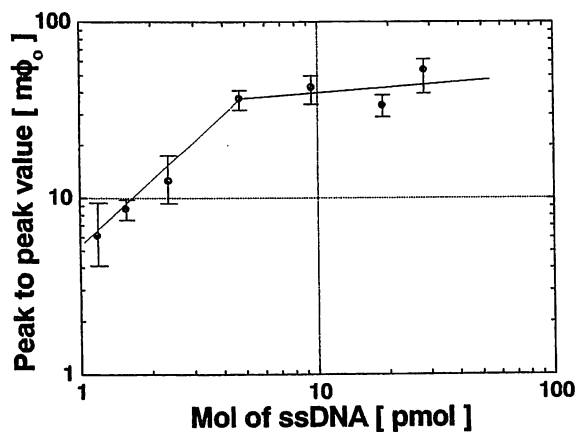

Fig.8. Magnetic signal v.s. mol of sample DNA. Horizontal axis shows the number of sample DNA applied to the probe DNA. Signal shows saturation at about 5 pmol of DNA.

## 5. Conclusions

DNA detection system using high Tc SQUID magnetometer was constructed and demonstrated. Single strand DNA (ssDNA) with relatively short length, 30 base pairs (Human Papillomavirus Probes 33) was used. A probe DNA was anchored on aldehyde coated substrate via amino group  $\text{NH}_2$ . Then a sample DNA labeled with nanoparticles  $\text{Fe}_3\text{O}_4$  was applied to the substrate so that the hybridization occurred. After wash of excess DNA, the magnetic signal from the particles are measured under ac magnetic field by a SQUID. As a result, it is found that the signal does not increase even if the number of the applied sample DNA was increased at more than 0.2-0.6 pmol, because the reaction is determined by the number of probe DNA on

the substrate. This result indicates that the hybridization was successfully done. At next stage, a negative results in case of the sample DNA that is not complementary each other should be performed.

## Acknowledgment

We wish to acknowledge Mr. M. Hasegawa and Mr. K. Murase of Meito Sangyo for providing the oxide nanoparticles.

## References

- [1] E. M. Southern 1975 Detection of specific sequences among DNA fragments separated by gel electrophoresis *J. Mol.*
- [2] M. Nishioka, T. Tanizoe, S. Katsura and A. Mizuno, "Micromanipulation of cells and DNA molecule", *J. Electrostatics*, vol. 35, 1995, pp. 83-91.
- [3] E. Harlow, D. Lane 1988 *Antibodies, A Laboratory Manual*, Cold Spring Harbor, NY, Cold Spring Harbor Laboratory.
- [4] R. Koetitz, H. Matz, L. Trahms, H. Kock, W. Weitschies, T. Rheinlader, W. Semmler and T. Bunte, "SQUID based remanence measurements for immunoassays", *IEEE Trans. Appl. Supercond.*, vol. 7, 1997, pp. 3678-3681.
- [5] K. Enpuku, D. Kuroda, T. Q. Yang and K. Yoshinaga, "High Tc SQUID system and magnetic marker for biological immunoassays", *Jpn. J. Appl. Phys.*, vol. 13, 2002, pp. 371-376.

- [6] S. Tanaka, A. Hirata, Y. Saito, T. Mizoguchi, Y. Tamaki, I. Sakita and Monden M , “Application of High Tc SQUID magnetometer for sentinel-lymph node biopsy”, IEEE Trans. Appl. Supercond., vol. 11, 2001, pp. 665-668.
- [7] Y.R. Chemla, H. L. Grossman, Y. Poon, R. McDermott, R. Stevens, M.D. Alper nad J. Clarke, ”Ultrasensitive magnetic biosensor for homogeneous immunoassay“, Proc. National Acad. Sciences of U.S.A. vol.97, 14268, 2000.
- [8] S. Katsura, T. Yasuda, K. Hirano, A. Mizuno and S. Tanaka, “Development of a new detection method for DNA molecule”, Institute of Physics Publishing Supercond. Sci. Technol., vol. 14, 2001, pp. 1131-1134.
- [9] S.Tanaka, O.Yamazaki, R.Shimizu and Y.Saito, "Windowless High Tc Superconducting Interference Device Microscope", Jpn. J. Appl. Phys. Vol. 38, pp. L505-507, 1999.
- [10] S.Tanaka, R.Shimizu, Y.Saito, K.Shin, "Development of a High-Tc SQUID Cryo-system for the Measurement of a Remanent Magnetic Field of Rock", IEICE Trans, vol. E-83-C, pp. 44-48, 2000.
- [11] M. Hasegawa, T. Hanaichi, H. Shoji, T. Kawaguchi and S. Maruno, “Biological behavior of dextran – iron oxide megantic fluid injected intravenously in rats”, Jpn. J. Appl. Phys. Vol. 37, pp. 1029-1032, 1998.
- [12] M. Schena, D. Shalon, R. Heller, A. Chai, P. O. Brown and R.W. Davis, “Parallel human genome analysis: Microarray-based expression monitoring of 1000 genes”, Proc. Natl. Acad. Sci. USA, vol. 93, 1996, pp. 10614-10619.